

ALL DIMENSIONS IN INCHES

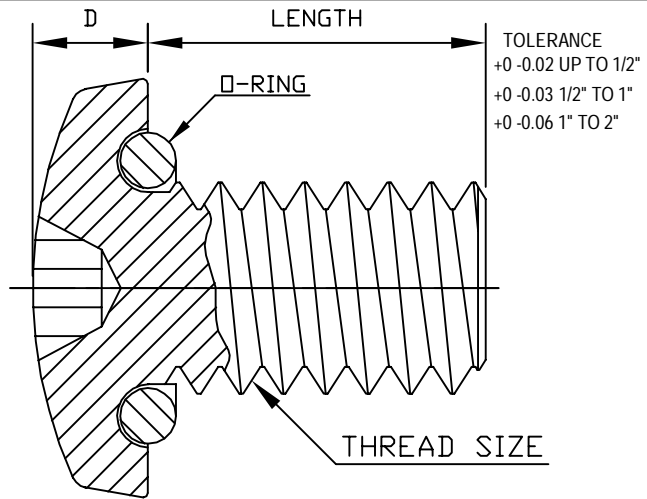

THREAD SIZE	C max	D max	Head Driver Size	INSTAL. TORQUE	RECOM. CLEAR. HOLE (max.)	LENGTH
2-56 UNC-2A	0.181"	0.062"	#1	2.5 inch lbs	0.095"	1/4" to 1" incl.
4-40 UNC-2A	0.238"	0.080"	#1	5.2 inch lbs	0.128"	3/16" to 1" incl.
6-32 UNC-2A	0.294"	0.097"	#2	9.6 inch lbs	0.149"	1/4" to 1" incl.
8-32 UNC-2A	0.347"	0.115"	#2	19.8 inch lbs	0.177"	1/4" to 1" incl.
10-24 UNC-2A	0.403"	0.133"	#2	22.8 inch lbs	0.201"	3/8" to 1" incl.
10-32 UNF-2A	0.403"	0.133"	#2	31.7 inch lbs	0.201"	3/8" to 1" incl.
1/4-20 UNC-2A	0.517"	0.175"	#3	75.2 inch lbs	0.250"	3/8" to 1 1/4" incl.
1/4-28 UNF-2A	0.517"	0.175"	#3	94 inch lbs	0.250"	5/16" to 1 1/4" incl.

TYPICAL CLEARANCE HOLE DETAIL

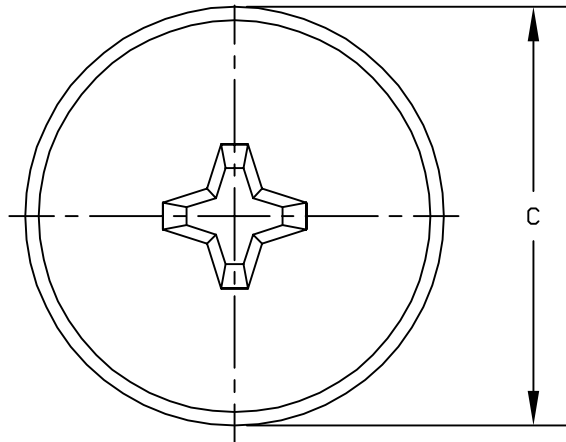
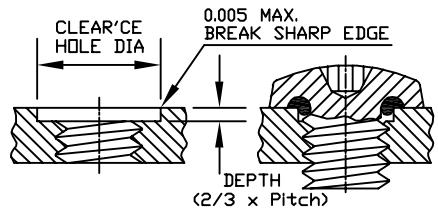

STANDARD SPECIFICATIONS & COMMON OPTIONS (HOW TO ORDER)

STD. SCREW MATERIAL: TYPE 18/8 STAINLESS STEEL PER DFARS (OTHER MATERIALS AVAILABLE)
 STD. SCREW FINISH: NATURAL (PASSIVATED QQ-P-35 UNLESS OTHERWISE SPECIFIED)
 STD. O-RING MATERIAL: SILICONE RUBBER (SEE TABLE FOR O-RING OPTIONS)

SAMPLE CATALOG NO.		R2-56X1/4-2701-BLKOX
SCREW TYPE	R	PAN HEAD WITH CROSS RECESS
THREAD	2-56	ENTER BASIC THREAD SIZE
	X	
LENGTH	1/4	ENTER LENGTH
O-RING SUFFIX	-2701	ENTER FROM TABLE
OPTIONS	-BLKOX	ENTER FROM TABLE

AVAILABLE O-RING MATERIALS		
Compound Suffix	Material	Service Temp.
-2701	Silicone Rubber	-150°F to 500°F -101°C to 260°C
-2615	Fluoro-Silicone Rubber	-78°F to 450°F -61°C to 232°C
-5701	Viton® A	-20°F to 400°F -29°C to 204°C
-4601	Buna N (NBR)	-65°F to 250°F -54°C to 121°C
-3701	Neoprene (EPR)	-65°F to 300°F -54°C to 149°C
-7601	Ethylene Propylene (EPDM)	-65°F to 300°F -54°C to 149°C

COMMON OPTIONS	
SUFFIX	DESCRIPTION
-BLKOX	BLACK OXIDE PER MIL-C-13924A, CLASS 2
-NY	LOCKING NYLON PELLET
-LY	LOCKING NYLON STRIP
-TP	LOCKING NYLON STD. PATCH
-HTP	HIGH TEMP. LOCKING NYLON PATCH

R	CHANGED MIN. LENGTH OF 4-40 UNC-2A FROM 1/4" TO 3/16"	S. GOK	07.12.10
P	CHANGED CLEAR. HOLE MAX and SCREW FINISH, TOOK OFF MIN. and ADDED INST. TORQUE	S. GOK	04.13.10
O	LENGTH TOLERANCES CHANGED ACCORDING TO "MS" STANDARD	S. GOK	03.10.10
N	ADDED "PER DFARS" FOR THE SCREW MATERIAL	S. GOK	07.02.09
M	NEW DRAWING FORMAT	S. GOK	01.21.09
L	CHANGED LENGTH TOLERANCE and ADDED Note	S. GOK	06.10.08

REV.	DESCRIPTION	DATE								
<table border="1"> <tr> <td rowspan="3">MAXIMUM AND MINIMUM MEASUREMENTS ARE STATED DIRECTLY ON EACH DIMENSION.</td> <td rowspan="3">TITLE: SEELSKREW ®, PAN HEAD CROSS RECESSED</td> <td>ENG. S. GOK</td> <td>06.10.08</td> </tr> <tr> <td>DWN. S. GOK</td> <td>06.10.08</td> </tr> <tr> <td>CHKD. J. CELLA</td> <td>06.10.08</td> </tr> </table>			MAXIMUM AND MINIMUM MEASUREMENTS ARE STATED DIRECTLY ON EACH DIMENSION.	TITLE: SEELSKREW ®, PAN HEAD CROSS RECESSED	ENG. S. GOK	06.10.08	DWN. S. GOK	06.10.08	CHKD. J. CELLA	06.10.08
MAXIMUM AND MINIMUM MEASUREMENTS ARE STATED DIRECTLY ON EACH DIMENSION.	TITLE: SEELSKREW ®, PAN HEAD CROSS RECESSED	ENG. S. GOK			06.10.08					
		DWN. S. GOK			06.10.08					
		CHKD. J. CELLA	06.10.08							
MAT'L: AS NOTED	APM-HEXSEAL CORPORATION	SCALE	DWG. NO. R-0000-00-00							
FINISH: AS NOTED										

THIS DRAWING COVERS PROPRIETARY ITEM AND IS THE PROPERTY OF THE APM-HEXSEAL CORPORATION.
 THIS DRAWING IS NOT TO BE COPIED OR USED WITHOUT THE WRITTEN APPROVAL OF AN OFFICER OF THE APM-HEXSEAL CORPORATION.